



# RACK CABINET



Upcom optical cable assemblies provide the vital connectivity links and patching for your network. Our in-house designed and specified assemblies provide 1 to 288 fibres featuring IEC compliant components and a choice of performance levels to suit your network needs.

## W-LINE WALL MOUNTING CABINET



### DESCRIPTION

The W-Line wall mounting rack cabinets are suitable in the offices for limited U height is required. W-Line 19" cabinets are protected by IP20. W-Line have two 19" adjustable mounting angles in depth. Additional mounting rails can be ordered as accessory. Front door with glass door and perforated metal door option is available. Having removable and lockable 2 side panels and metal rear panelç Load carrying capacity is 50 kg in case used as a wall mounting cabinet and load carrying capacity can go up to 200 kg in case used as a free standing cabinet. Colour options are RAL 9005 Black, and RAL 7035 Light Grey, with fine wrinkle soft touch paint.

Vented top cover provides passive air circulation via convection. There is a double vented fan hole suitable for optimum cooling of fan. Two 19" adjustable angled mounting rails could be moved forward and backward. Door is having a glass door. It is lockable and removable. Side Panels are removable and lockable. Enabling you to easy access to equipment and gives better look and improved security Back Panel; could be removable and be mountable on the wall easily. There are two brushed cable entry at W-Line cabinet 1 on Bottom 1 on Top.

**Heights** : 4U, 7U, 9U, 12U, 16U, 20U

**Depth** : 450mm & 600mm

**Width** : 550mm

### CONSTRUCTION

**Door** : Front door with glass door and perforated metal door option is available.

**Material** : A1 quality steel HDG, body thickness is 2 mm, mounting rails are 1,5 mm thick.

**Cable Entry** : On Top and bottom cable brushed entry.

**Mounting Rail** : 2 pcs of 19" adjustable mounting rails. Compatible with standard international 19 inch standard.

**Side Panels** : Opening, lockable.

**Painting** : Impact-resistant, Electrostatic powder painting. Color options are RAL 9005 Black & RAL 7035 White.

**Rear Panel** : Can be removable and be mountable on the wall easily. W-Line Wall mounting cabinets can easily be transformed to double sectioned cabinet in a second with the help of its well-engineered construction. You shall order the rear section for that option.

**IP 20 rating** : IP20 according to EN61587-1, IEC60529. Protected against solid objects larger than 12,5 mm in diameter.

# W-LINE WALL MOUNTING CABINET

## DRAWINGS

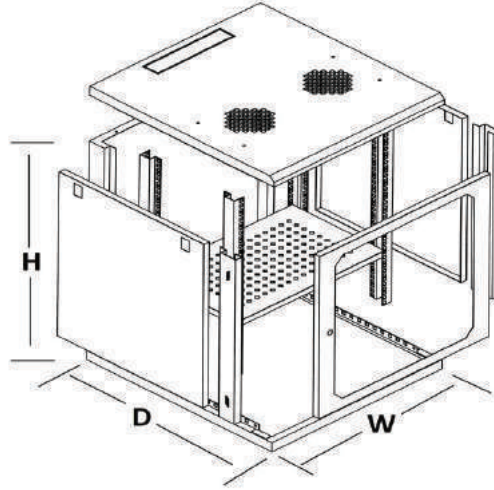

## Exploded View

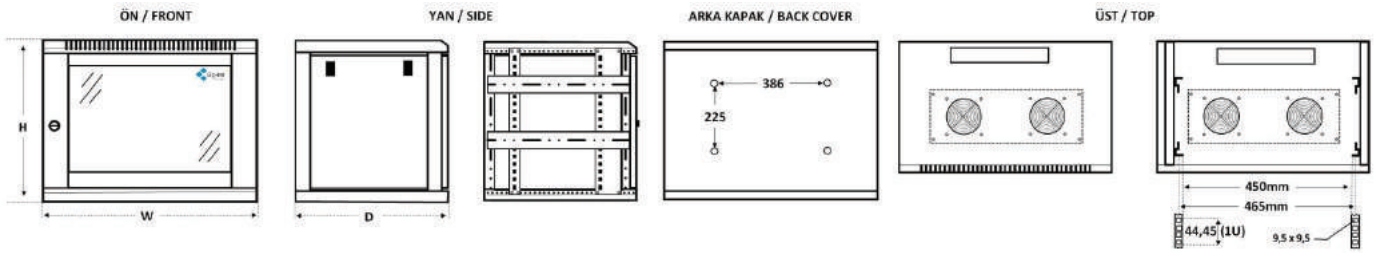

## Rear Section

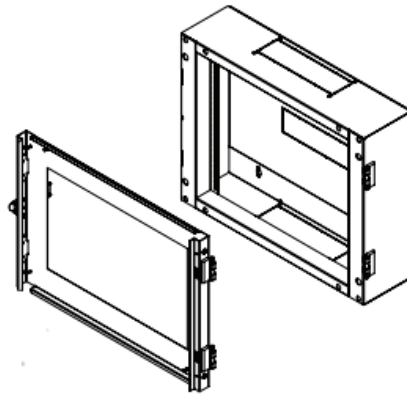

# W-LINE WALL MOUNTING CABINET



- 19" mounting to IEC 297-1
- EN 61587-1 mechanical structures (cabinets for electronic equipment)
- Overall cabinet dimensions for IEC 297-2 EN 61587 -1:2012 Mechanical Structures for Electronic Equipment
- IEC 297-1, 19" mounting
- IEC 297-2 Overall cabinet dimensions
- Corrosion Resistance: ISO9227 and ASTM B 117-85



ISO 9001:2008 Quality Management System



ISO 14001 Environmental Management System  
%100 Recyclable Material



CE conform to EN 60950-1:2006 Information Technology Equipment – Safety – Part 1-



RoHS Compliancy



Ordering Code	Description	Gross Weight in kg
UP-4UDVT-550X450	4U 550x450 Wall Mounting Cabinet	10
UP-4UDVT-550X600	4U 550x600 Wall Mounting Cabinet	14
UP-7UDVT-550X450	7U 550x450 Wall Mounting Cabinet	14
UP-7UDVT-550X600	7U 550x600 Wall Mounting Cabinet	19
UP-9UDVT-550X450	9U 550x450 Wall Mounting Cabinet	17
UP-9UDVT-550X600	9U 550x600 Wall Mounting Cabinet	21
UP-12UDVT-550X450	12U 550x450 Wall Mounting Cabinet	22
UP-12UDVT-550X600	12U 550x600 Wall Mounting Cabinet	25,5
UP-15UDVT-550X450	15U 550x450 Wall Mounting Cabinet	26
UP-15UDVT-550X600	15U 550x600 Wall Mounting Cabinet	29
UP-19UDVT-550X450	19U 550x450 Wall Mounting Cabinet	30
UP-19UDVT-550X600	19U 550x600 Wall Mounting Cabinet	32
UP-20UDVT-550X450	20U 550x450 Wall Mounting Cabinet	32
UP-20UDVT-550X600	20U 550x600 Wall Mounting Cabinet	34

CC: Please indicate the color code at the end of product code. BL: RAL 9005 Black & LG: RAL 7035 Light Grey/White.

## W-LINE WALL MOUNTING CABINET ACCESSORIES

### FAN MODULES



### DESCRIPTION

Single and Double Fan module are available and compatible. Digital Thermostat is available at fan modules. Compatible with all model and brands of cabinets. Plug and play with on/off switches and plugs. Air removal capacity is 2.3-3 m<sup>3</sup>/minutes.

Colour : RAL 9005 Black & RAL 7035 White.

### TECHNICAL SPECIFICATION

- 13,8/11,8W, 220/240 VAC
- 50/60 Hz, 0,07/0,06A, 2550/2750 rpm
- 42-47 dB noise level,
- Product Life 50.000 hours (40°C).
- Operating temperature range -10°C ~ +70°C

Ordering Code	Description
UP-FMDF1T	1xFan Module Digital Thermostat
UP-FMDF2T	2x Fan Module Digital Thermostat
UP-FMDF4T	4x Fan Module Digital Thermostat
UP-FMONF1	1xFan Module with On/Switch
UP-FMONF2	2xFan Module with On/Switch
UP-FMONF4	4xFan Module with On/Switch

CC: Please indicate the color code at the end of product code. BL: RAL 9005 Black & LG: RAL 7035 Light Grey/White.

## W-LINE WALL MOUNTING CABINET ACCESSORIES

### POWER DISTRIBUTION UNITS (PDUs)



### DESCRIPTION

Upcom's W-Line serie of PDUs range is engineered for simple, reliable and cost-effective power distribution, All ECO serie PDUs come in both horizontal and vertical type. 1U,2U, 19" 16A with an of/off lighting switched, in black color, aluminium Housing. Horizontal PDUs mount easily in any standard EIA 19-inch rack, while vertical PDUs are ideal for mounting within a cabinet's Zero-U space.

Ordering Code	Description
UP-PRZ-PW3	3 Way PDU, Cct breaker, 1x16A, 250V, 4000W, Halogenfree, Aluminium Housing, 2m Cable
UP-PRZ-PW6	6 Way PDU, Cct breaker, 1x16A, 250V, 4000W, Halogenfree, Aluminium Housing, 2m Cable
UP-PRZ-PW8	8 Way PDU, Cct breaker, 1x16A, 250V, 4000W, Halogenfree, Aluminium Housing, 2m Cable
UP-PRZ-PW9	9 Way PDU, Cct breaker, 1x16A, 250V, 4000W, Halogenfree, Aluminium Housing, 2m Cable
UP-PRZ-PW12	12 Way PDU, Cct breaker, 1x16A, 250V, 4000W, Halogenfree, Aluminium Housing, 2m Cable

## W-LINE WALL MOUNTING CABINET ACCESSORIES

### FIXED & SLIDING SHELVES

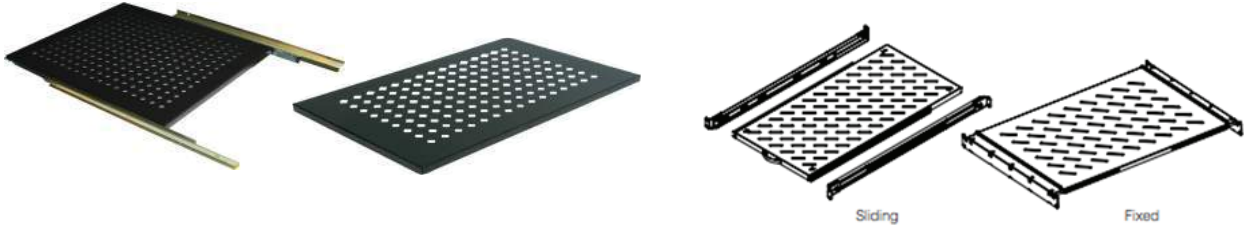

### DESCRIPTION

19" shelves are the ideal accessory for your server and network installations. Made of steel with a thickness of 1,2 mm. Surface finish: degreasing, etching, phosphating, powder coating. Protected against rust, oxidation, scratches and corrosion. Compliant with ANSI/EIA RS-310-D, DIN41491 PART1, IEC297-2, DIN41494 PART7, and GB/T3047.2-92 standards. Compatible with metric ETSI and 19-inch international standards. Fixing points at the sides of rear and front 19" mounting angles. Vented for air circulation. Adjustable depth. Made of steel sheet. Load carrying capacity is 50 kg for fixed shelves, 25 kg for sliding shelves. Compatible with all brand cabinets. Color options are RAL 9005 Black & RAL 7035 White.

Ordering Code	Dimensions (WxD)	Description
UP-RF-SAR250	47 x 25	Fixed Shelf 250 mm for D:400mm. Cabinets
UP-RF-YSBR600	47 x 30	Fixed Shelf 300 mm for D:600mm Cabinets
UP-RF-HR600	47 x 30	Sliding Shelf 300 mm for D:600mm Cabinets

CC: Please indicate the color code at the end of product code. BL: RAL 9005 Black & LG: RAL 7035 Light Grey/White.

## W-LINE WALL MOUNTING CABINET ACCESSORIES

### HORIZONTAL CABLE MANAGER



#### DESCRIPTION

The range is suitable for all 19" applications. Made of sheet steel, easy to install and mount. Having 5 rings at each.

Ordering Code	Description
UP-ORG1U	1U Cable Organizer with 5 Rings
UP-ORG2U	2U Cable Organizer with 5 Rings

### BLANK PANEL

#### DESCRIPTION

Blank panel is the perfect option to block the unused rack space and to improve both cooling efficiency and prevent air re-circulation. Fits for standard EIA-310-D compliant rails. Blank panel is for a Rack Panel made of 14-gauge steel with glossy Black or White finish.



Ordering Code	Description
UP-KPP1U	1U 19" Blank Panel Screwed Type
UP-KPP2U	2U 19" Blank Panel Screwed Type

CC: Please indicate the color code at the end of product code. BL: RAL 9005 Black & LG: RAL 7035 Light Grey/White.



## W-LINE WALL MOUNTING CABINET ACCESSORIES

### CASTORS & LEVELLING FEET



### DESCRIPTION

Ball bearing, swivel and hard composition wheels. They can move any direction you like to drive. 2 ea. front are lockable. Load capacity for each castor is for fixed 50 kg and moving 25kg. Load capacity for each levelling feet is 250 kg. Levelling feet allowing you to adjust height of the feet.

Ordering Code	Description
UP-WM-LF-4G	Leveling Feet 1 set(4 pcs)
UP-WM-CS-4G	Castors Set 1 set(4 pcs)

### FIXINGS

Cage Nut Set 20pcs each set including Screws, Nuts, Plastic Washers M6. Suitable for rack mount fixing the patch panels, switches, PDU on cabinet.



Ordering Code	Description
UP-CNS-20P	Fixings: Screw 20pcs, Washer 20pcs, Cage nut 20pcs

## FS-LINE FREE STANDING CABINET

### DESCRIPTION

FS-Line free standing cabinets provide a robust, cost-effective enclosure solution. PDU mounting or connectivity on both the front and rear of the cabinet. The FS-Line cabinet is ideal for high-density data center environments, enabling increased cabling and equipment density while providing excellent accessibility and thermal efficiency. All of these features are integrated into a full-featured modular enclosure that is equally effective as a standalone network and server cabinet.



### CONSTRUCTION

- Door** : Front door with glass door and perforated metal door option is available.
- Material** : A1 quality steel HDG, carriers are 2 mm, mounting, the poles 1,5 mm.
- Cable Entry** : On Top and bottom cable entry. Multiple cable entry points provide maximum versatility.
- Mounting Rail** : 4 pcs of 19" adjustable mounting rails. Compatible with standard international 19 inch standard.
- Side Panels** : Opening & lockable.
- Painting** : Impact-resistant, Electrostatic powder painting. Color options are RAL 9005 Black & RAL 7035 White.
- Rear Panel** : Can be removable and be mountable easily.
- IP 20 rating** : IP20 according to EN61587-1, IEC60529. Protected against solid objects larger than 12,5 mm in diameter.

**Heights** : 12U, 15U, 16U, 19U, 20U, 25U, 27U, 30U 33U 35U 37U 39U 42U 45U

**Width & Depth** : 600x600mm  
600x800mm  
600x1000mm  
800x800mm  
800x1000mm

# FS-LINE FREE STANDING CABINET

## DRAWINGS

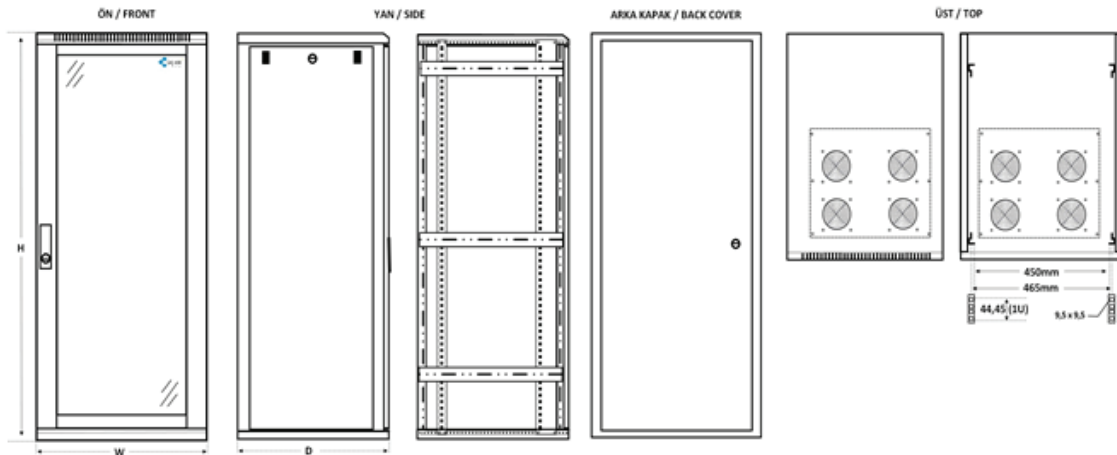
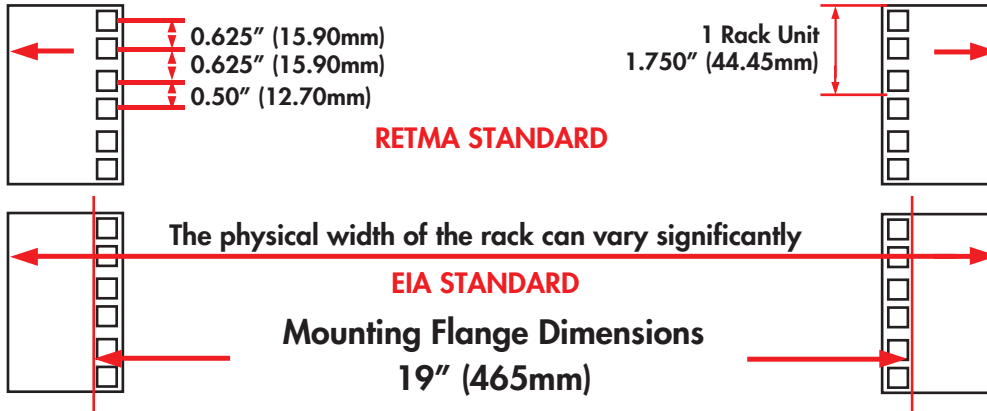
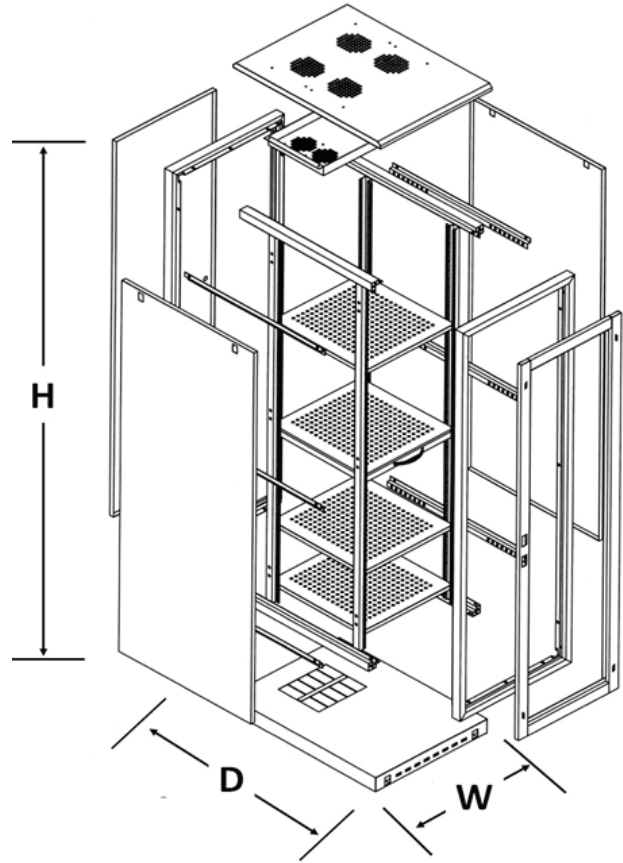

## FS-LINE FREE STANDING CABINET



- ISO 9001:2000 TSE:EN 61587-1 Mechanical Structures For Electronic Equipment - Tests For IEC 60917 And IEC 60297
- Climatic and Environment: EN 61587-1/4.2, IEC60068-2-1, IEC60068-2-2, IEC60068-2-30,
- Static Mechanical Load Lifting: EN61587-1/5.2.1
- Static Mechanical Load Stiffness: EN61587-1/5.2.2
- Dynamic Mechanical Load Vibration and Shock, Impact: EN61587-1/5.3.1, EN61587-1/5.3.3, IEC60068-2-6, IEC60068-2-27,
- Earth Bond: EN61587-1/6.2
- Flammability: EN61587-1/6.3
- Degrees Of Protection Provided By Enclosures (Ip Code): IP20 or IP55, EN61587-1/6.4
- Load Carrying Capacity: 600 kg
- Surface Treatment: Fosfat coating
- Corrosion Resistance: ISO9227 and ASTM B 117-85
- Painting: Ral7035 / Ral9005



ISO 9001:2008 Quality Management System



ISO 14001 Environmental Management System  
%100 Recyclable Material



CE conform to EN 60950-1:2006  
Information Technology  
Equipment – Safety – Part-1-



RoHS Compliancy

## FS-LINE FREE STANDING CABINET



Ordering Code	Description	Gross Weight in kg
UP-16UYRT-600X600	16U-600X600-19" Free Standing Cabinets	47
UP-16UYRT-600X800	16U-600X800-19" Free Standing Cabinets	60
UP-16UYRT-600X1000	16U-600X1000-19" Free Standing Cabinets	66
UP-16UYRT-800X800	16U-800X800-19" Free Standing Cabinets	70
UP-16UYRT-800X1000	16U-800X1000-19" Free Standing Cabinets	83
UP-20UYRT-600X600	20U-600X600-19" Free Standing Cabinets	54
UP-20UYRT-600X800	20U-600X800-19" Free Standing Cabinets	65,2
UP-20UYRT-600X1000	20U-600X1000-19" Free Standing Cabinets	69,5
UP-20UYRT-800X800	20U-800X800-19" Free Standing Cabinets	73
UP-20UYRT-800X1000	20U-800X1000-19" Free Standing Cabinets	92
UP-25UYRT-600X600	25U-600X600 -19" Free Standing Cabinets	60
UP-25UYRT-600X800	25U-600X800 -19" Free Standing Cabinets	72
UP-25UYRT-600X1000	25U-600X1000-19" Free Standing Cabinets	80,5
UP-25UYRT-800X800	25U-800X800-19" Free Standing Cabinets	84
UP-25UYRT-800X1000	25U-800X1000-19" Free Standing Cabinets	105
UP-27UYRT-600X600	27U-600X600-19" Free Standing Cabinets	62,7
UP-27UYRT-600X800	27U-600X800-19" Free Standing Cabinets	74,5
UP-27UYRT-600X1000	27U-600X1000-19" Free Standing Cabinets	86
UP-27UYRT-800X800	27U-800X800-19" Free Standing Cabinets	91
UP-27UYRT-800X1000	27U-800X1000-19" Free Standing Cabinets	110
UP-30UYRT-600X600	30U-600X600-19" Free Standing Cabinets	66,9
UP-30UYRT-600X800	30U-600X800-19" Free Standing Cabinets	78,5
UP-30UYRT-600X1000	30U-600X1000-19" Free Standing Cabinets	93
UP-30UYRT-800X800	30U-800X800-19" Free Standing Cabinets	98
UP-30UYRT-800X1000	30U-800X1000-19" Free Standing Cabinets	118
UP-33UYRT-600X600	33U-600X600-19" Free Standing Cabinets	70,8
UP-33UYRT-600X800	33U-600X800-19" Free Standing Cabinets	82,5
UP-33UYRT-600X1000	33U-600X1000-19" Free Standing Cabinets	100
UP-33UYRT-800X800	33U-800X800-19" Free Standing Cabinets	105
UP-33UYRT-800X1000	33U-800X1000-19" Free Standing Cabinets	125
UP-37UYRT-600X600	37U-600X600-19" Free Standing Cabinets	76,2
UP-37UYRT-600X800	37U-600X800-19" Free Standing Cabinets	87,5
UP-37UYRT-600X1000	37U-600X1000-19" Free Standing Cabinets	109
UP-37UYRT-800X800	37U-800X800-19" Free Standing Cabinets	114
UP-37UYRT-800X1000	37U-800X1000-19" Free Standing Cabinets	133
UP-39UYRT-600X600	39U-600X600-19" Free Standing Cabinets	78,9
UP-39UYRT-600X800	39U-600X800-19" Free Standing Cabinets	90
UP-39UYRT-600X1000	39U-600X1000-19" Free Standing Cabinets	114
UP-39UYRT-800X800	39U-800X800-19" Free Standing Cabinets	119
UP-39UYRT-800X1000	39U-800X1000-19" Free Standing Cabinets	140
UP-42UYRT-600X600	42U-600X600-19" Free Standing Cabinets	83
UP-42UYRT-600X800	42U-600X800-19" Free Standing Cabinets	94
UP-42UYRT-600X1000	42U-600X1000-19" Free Standing Cabinets	121
UP-42UYRT-800X800	42U-800X800-19" Free Standing Cabinets	126
UP-42UYRT-800X1000	42U-800X1000-19" Free Standing Cabinets	137
UP-45UYRT-600X600	45U-600X600-19" Free Standing Cabinets	88
UP-45UYRT-600X800	45U-600X800-19" Free Standing Cabinets	98
UP-45UYRT-600X1000	45U-600X1000-19" Free Standing Cabinets	128
UP-45UYRT-800X800	45U-800X800 -19" Free Standing Cabinets	133
UP-45UYRT-800X1000	45U-800X1000-19" Free Standing Cabinets	143

CC: Please indicate the color code at the end of product code. BL: RAL 9005 Black & LG: RAL 7035 Light Grey/White.

## FS-LINE FREE STANDING CABINET ACCESSORIES

### FAN MODULES



### DESCRIPTION

Single and Double Fan module are available and compatible. Digital Thermostat is available at fan modules. Compatible with all model and brands of cabinets. Plug and play with on/off switches and plugs. Air removal capacity is 2.3-3 m<sup>3</sup>/minutes.

Colour : RAL 9005 Black & RAL 7035 White.

### TECHNICAL SPECIFICATION

- 13,8/11,8W, 220/240 VAC
- 50/60 Hz, 0,07/0,06A, 2550/2750 rpm
- 42-47 dB noise level,
- Product Life 50.000 hours (40°C).
- Operating temperature range -10°C ~ +70°C

Ordering Code	Description
UP-FMDF1T	1xFan Module Digital Thermostat
UP-FMDF2T	2xFan Module Digital Thermostat
UP-FMDF4T	4xFan Module Digital Thermostat
UP-FMONF1	1xFan Module with On/Switch
UP-FMONF2	2xFan Module with On/Switch
UP-FMONF4	4xFan Module with On/Switch

CC: Please indicate the color code at the end of product code. BL: RAL 9005 Black & LG: RAL 7035 Light Grey/White.

## FS-LINE FREE STANDING CABINET ACCESSORIES

### POWER DISTRIBUTION UNITS (PDUs)



#### DESCRIPTION

Upcom's W-Line serie of PDUs range is engineered for simple, reliable and cost-effective power distribution, All ECO serie PDUs come in both horizontal and vertical type. 1U,2U, 19" 16A with an of/off lighting switched, in black color, aluminium Housing. Horizontal PDUs mount easily in any standard EIA 19-inch rack, while vertical PDUs are ideal for mounting within a cabinet's Zero-U space.

Ordering Code	Description
UP-PRZ-PW3	3 Way PDU, Cct breaker, 1x16A, 250V, 4000W, Halogenfree, Aluminium Housing, 2m Cable
UP-PRZ-PW6	6 Way PDU, Cct breaker, 1x16A, 250V, 4000W, Halogenfree, Aluminium Housing, 2m Cable
UP-PRZ-PW8	8 Way PDU, Cct breaker, 1x16A, 250V, 4000W, Halogenfree, Aluminium Housing, 2m Cable
UP-PRZ-PW9	9 Way PDU, Cct breaker, 1x16A, 250V, 4000W, Halogenfree, Aluminium Housing, 2m Cable
UP-PRZ-PW12	12 Way PDU, Cct breaker, 1x16A, 250V, 4000W, Halogenfree, Aluminium Housing, 2m Cable

CC: Please indicate the color code at the end of product code. BL: RAL 9005 Black & LG: RAL 7035 Light Grey/White.

## FS-LINE FREE STANDING CABINET ACCESSORIES

### FIXED & SLIDING SHELVES



### DESCRIPTION

19" shelves are the ideal accessory for your server and network installations. Made of steel with a thickness of 1,2 mm. Surface finish: degreasing, etching, phosphating, powder coating. Protected against rust, oxidation, scratches and corrosion. Compliant with ANSI/EIA RS-310-D, DIN41491 PART1, IEC297-2, DIN41494 PART7, and GB/T3047.2-92 standards. Compatible with metric ETSI and 19-inch international standards. Fixing points at the sides of rear and front 19" mounting angles. Vented for air circulation. Adjustable depth. Made of steel sheet. Load carrying capacity is 50 kg for fixed shelves, 25 kg for sliding shelves. Compatible with all brand cabinets. Color options are RAL 9005 Black & RAL 7035 White.

Ordering Code	Description
UP-RF-YSBR600	Fixed Shelf - 300 mm. for Cabinets having D:600mm.
UP-RF-YSBR800	Fixed Shelf - 500 mm. or Cabinets having D:800mm.
UP-RF-YSBR1000	Fixed Shelf - 720 mm. or Cabinets having D:1000mm.
UP-RF-HR600	Sliding Shelf 300 mm. For Cabinets having D:600mm.
UP-RF-HR800	Sliding Shelf 500 mm. For Cabinets having D:800mm.
UP-RF-HR1000	Sliding Shelf 720 mm. For Cabinets having D:1000mm.

CC: Please indicate the color code at the end of product code. BL: RAL 9005 Black & LG: RAL 7035 Light Grey/White.



## FS-LINE FREE STANDING CABINET ACCESSORIES

### HORIZONTAL CABLE MANAGER



#### DESCRIPTION

The range is suitable for all 19" applications. Made of sheet steel, easy to install and mount. Having 5 rings at each.

Ordering Code	Description
UP-ORG1U	1U Cable Organizer with 5 Rings
UP-ORG2U	2U Cable Organizer with 5 Rings

CC: Please indicate the color code at the end of product code. BL: RAL 9005 Black & LG: RAL 7035 Light Grey/White.

### BLANK PANEL

#### DESCRIPTION

Blank panel is the perfect option to block the unused rack space and to improve both cooling efficiency and prevent air re-circulation. Fits for standard EIA-310-D compliant rails. Blank panel is for a Rack Panel made of 14-gauge steel with glossy Black or White finish.



Ordering Code	Description
UP-KPP1U	1U 19" Blank Panel Screwed Type
UP-KPP2U	2U 19" Blank Panel Screwed Type

CC: Please indicate the color code at the end of product code. BL: RAL 9005 Black & LG: RAL 7035 Light Grey/White.

## FS-LINE FREE STANDING CABINET ACCESSORIES

### CASTORS & LEVELLING FEET



### DESCRIPTION

Ball bearing, swivel and hard composition wheels. They can move any direction you like to drive. 2 ea. front are lockable. Load capacity for each castor is for fixed 50 kg and moving 25kg. Load capacity for each levelling feet is 250 kg. Levelling feets allowing you to adjust height of the feet.

Ordering Code	Description
UP-WM-LF-4G	Leveling Feet 1 set(4 pcs)
UP-WM-CS-4G	Castors Set 1 set(4 pcs)

### FIXINGS

Cage Nut Set 20pcs each set including Screws, Nuts, Plastic Washers M6. Suitable for rack mount fixing the patch panels, switches, PDU on cabinet.



Ordering Code	Description
UP-CNS-20P	Fixings: Screw 20pcs, Washer 20pcs, Cage nut 20pcs