

# SOHO LINE

RACK CABINET



RACK CABINETS

UPCOM

UPCOM

## ABOUT US

Upcom is a Turkish company and its Head Office is located in Turkey. Its broad range of product portfolio includes Fiber Optic & Copper Cables, Fiber & Copper Connectivity solutions for data center, Network equipments and Outdoor Field 19" Cabinets. We are the exporting member of associated Turkish Network products manufacturers of Fiber Optic Cables, 19" Rack Cabinets, cable blowing machine produced in Turkey

### Our Vision

Profitable and sustainable growth to ensure long-term customer and employee satisfaction, and satisfaction as well as aims.

### Our Mission

High standards, quality service in the time of our customers to maximize customer satisfaction and respect the rights. Our products, solutions, after sales service we provide our customers with reliability and high business ethics as the first choice to be a company that creates value for our employees and our customers.

# UPCOM

**The Faster. The Better.**

[www.upcom.com.tr](http://www.upcom.com.tr)

### Our Quality Policy

*The fact that customer satisfaction as a priority action in this direction is to provide products and services.*

*For this reason,*

- *Complying with the terms of the quality management system, to sustain activity.*

- *Ethics, values, respect and team spirit, and the potential to increase customer satisfaction.*

- *Improve the competitiveness of the industry by continuously improving staff satisfaction and education.*

- *Our employees, customers, suppliers long-term commitment to our organizations and institutions to increase non-cooperation.*

- *The provisions of relevant laws and standards to export to the framework.*

# RACK CABINETS



# RACK CABINET IS OUR PROFESSION



## Description

SOHO Wall Mount cabinets are engineered to accommodate 10" or 19" mounted equipment, including patch panels, shelves, SOHO active elements, and to be compact. SOHO Line Wall mount rack cabinets are suitable for small offices and households. SOHO Line is designed for structured premise cabling in local area networks, including distribution and equipment, cross connect cabinets and racks, splice boxes, climate control and many more components for both copper and fiber optic cabling systems.

## Standard & EU Directives Conformance

- Mechanical structure conforming to EN 61587-1
- Corrosion resistance (salt spray) acc. to ISO 9227, ASTM B117
- EU Directive 2011/65/EU (RoHS-2)

## Features

IP rating IP20  
Available in up to 12U heights  
Compact design with easy installation  
Powder Coated Electrostatic Paint in RAL 7035 or RAL 9005  
Glass door/Metal Door  
4mm impact resistant smoked glass  
10" or 19" galvanized profile rails  
Roof is prepared for fan units (punched out entries)



Galvanized rails

OPTIONAL



Hinge

STAINLESS STEEL



Full glass

SMOKY GREY



Packing

# DRAWING LINE

DRAWING

19" SOHO Network wall Mounting Cabinets

Width: 550 mm  
Depth: 400 mm

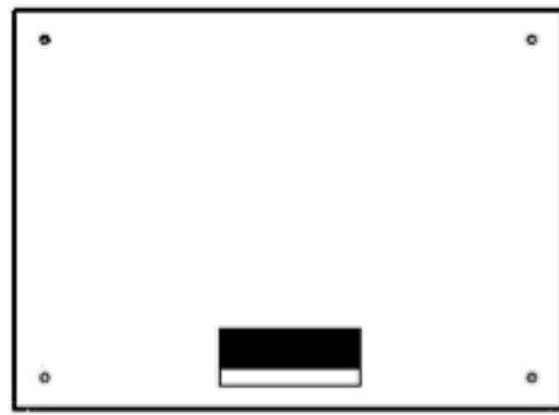

BOTTOM VIEW

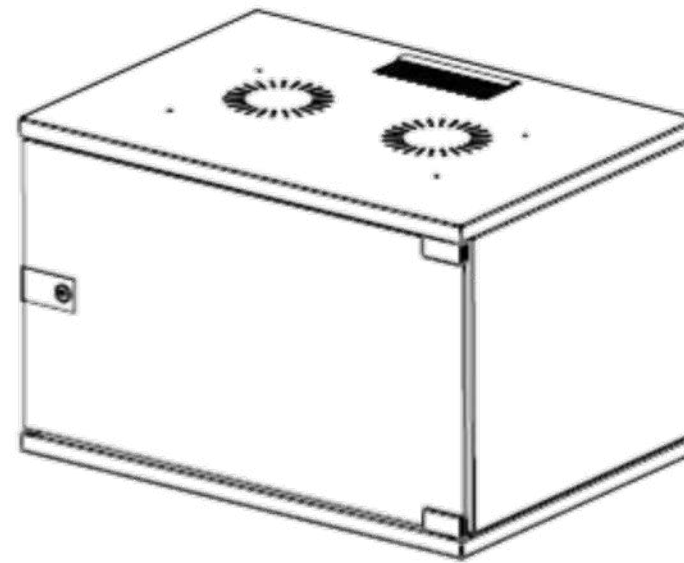

ISOMETRIC VIEW

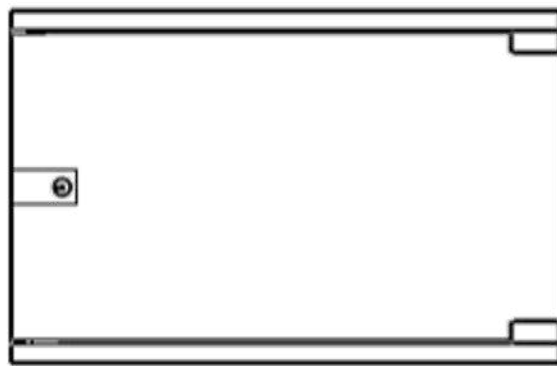

FRONT VIEW



SIDE VIEW

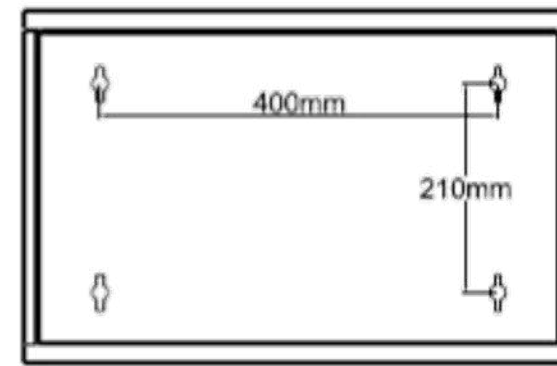

REAR VIEW

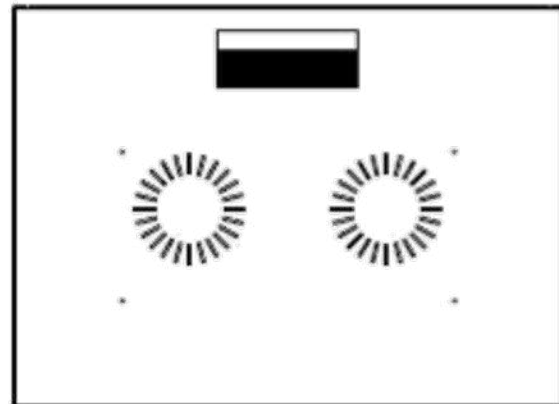

TOP VIEW

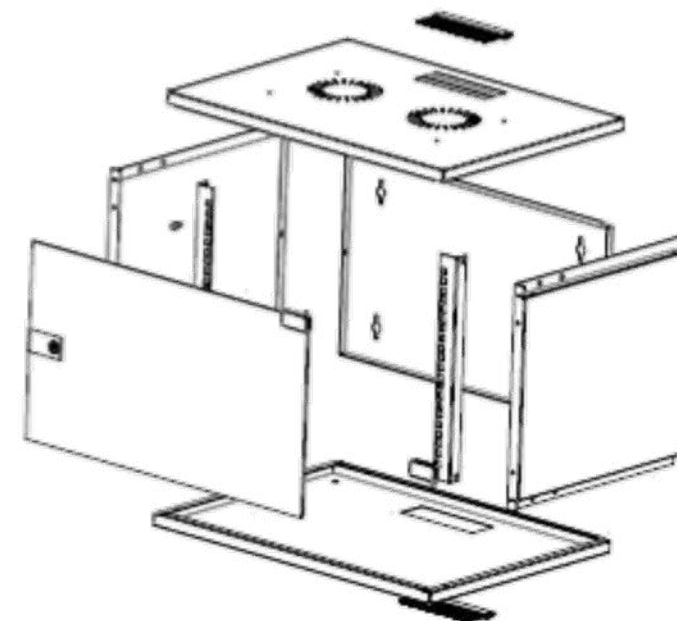

EXPLODED VIEW

# DRAWING LINE

DRAWING

19" SOHO Network wall Mounting Cabinets

Width: 550 mm

Depth: 400 mm

D=400mm

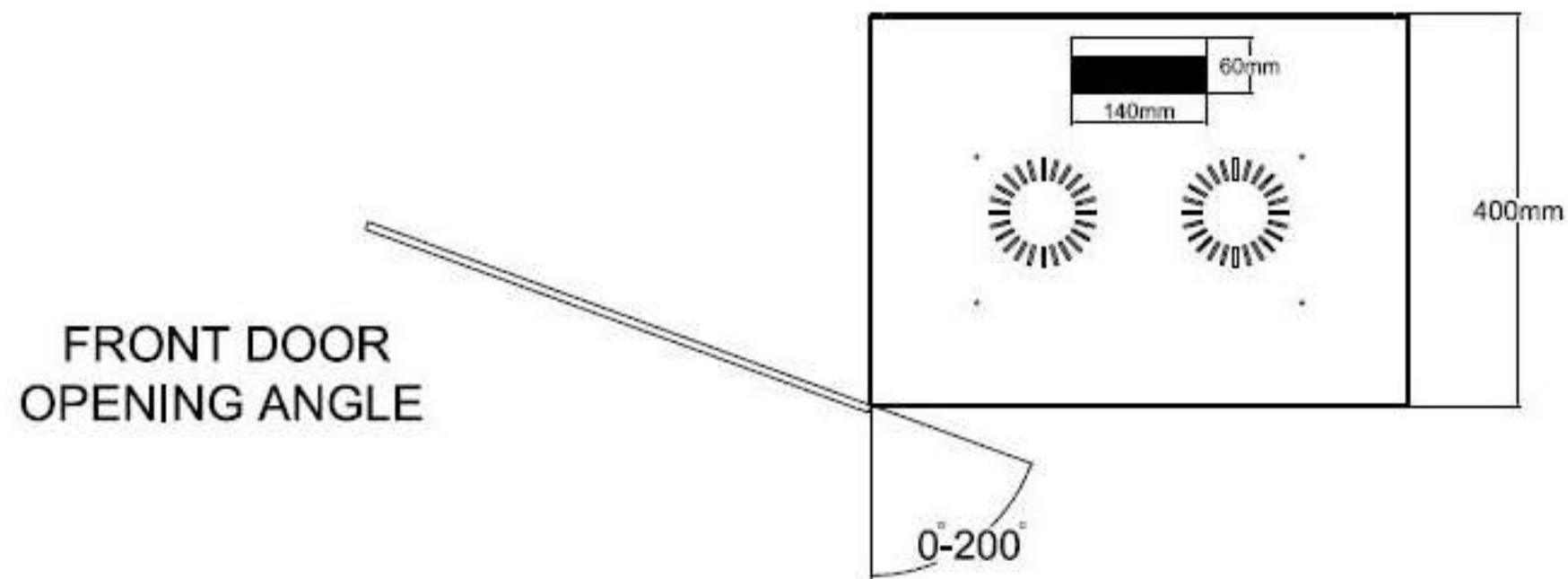

DIMENSIONS IN  
WIDTH AND HEIGHT

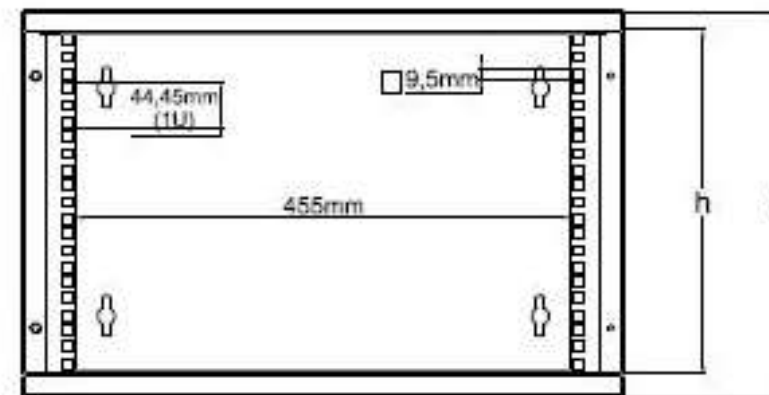

MAX/ STD / MIN  
EQUIPMENT  
MOUNTING DISTANCE

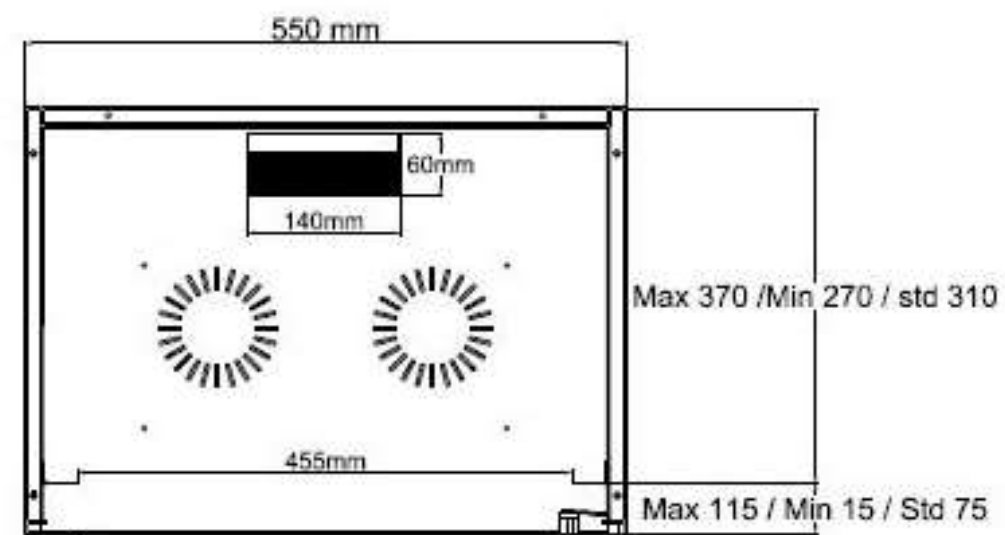

# DRAWING LINE

DRAWING

19" SOHO Network wall Mounting Cabinets

Width: 550 mm  
Depth: 400 mm

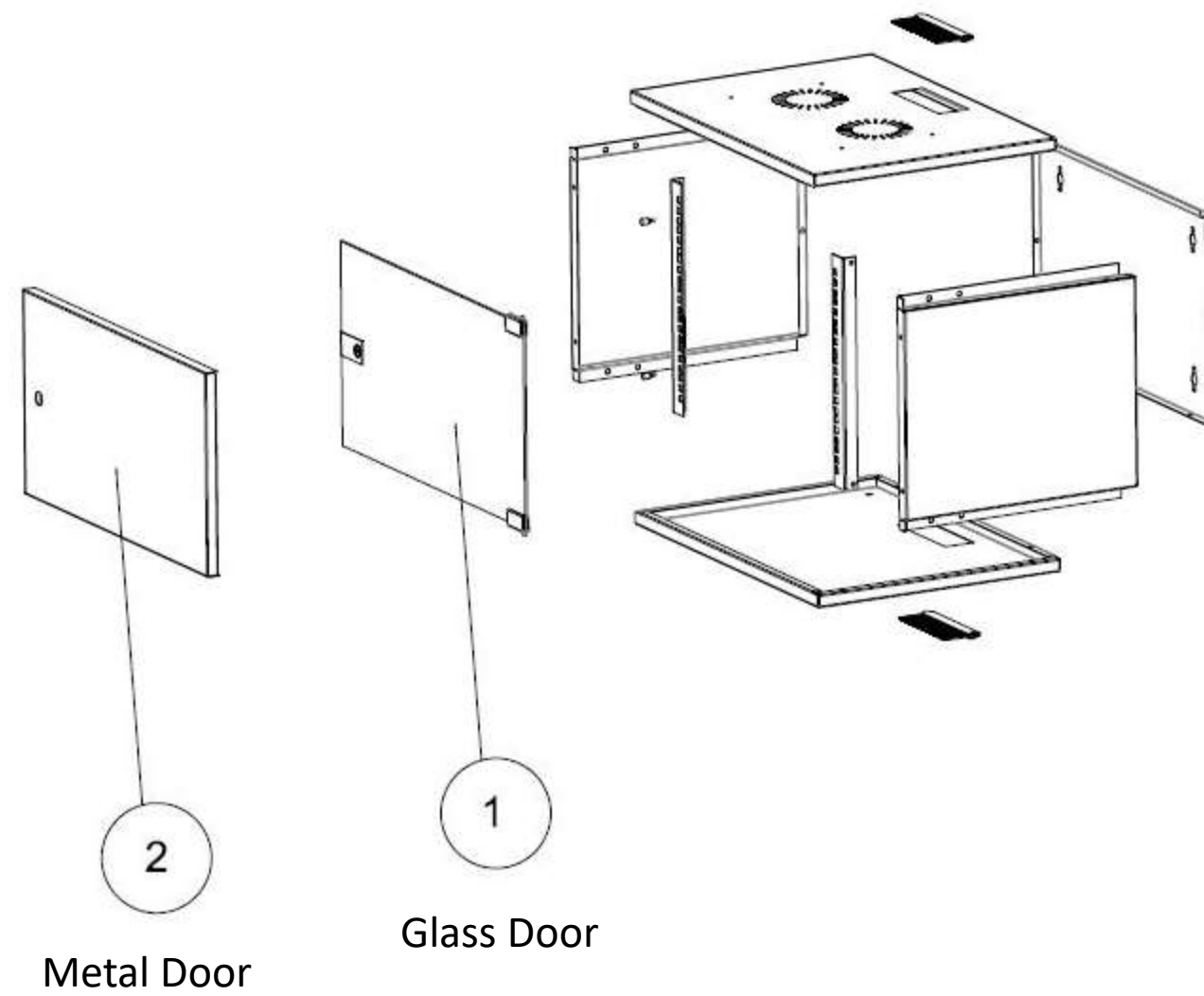

# EC DECLARATION OF CONFIRMITY

UPCOM TELEKOMUKASYON BİLİŞİM TEKNOLOJİLERİ URUNLERİ SAN. VE TIC. LTD. STI.

According to Preparation and Application of Technical Legislation on products  
of law No: 4703.

Declaration:

Herewith we declare under our own responsibility that the products  
designated below

Products:

Rack Cabinet

are manufactured in accordance with the EC Directives

Directives:

Managing Director:

Kenan ABALI

Directives

Low Voltage Directive (LVD) (2014/35/EU)

Electromagnetic Compatibility Directive (EMC) 2014/30/EU

Regulation of Safety of Machinery (2006/42/EC)

Istanbul, 2018

CE

**UPCOM**  
The Faster. The Better.

RACK CABINET



**UPCOM**  
The Faster. The Better.

FIBER OPTIC CABLE BLOWING MACHINES

ISTANBUL, TURKEY

☎ 0090 535 765 18 57

🌐 [www.upcom.com.tr](http://www.upcom.com.tr)

✉ [info@upcom.com.tr](mailto:info@upcom.com.tr)