



19" Server Cabinet Series

Overview

FS-Line Server cabinets provide a robust, cost-effective enclosure solution for your server requirements with professional ventilation structure as well the heavy duty construction to house the heavy loads of servering equipments. Front and Rear Doors are in standard % 65 (80% is available) perforated with handled locking 3 point locking system.

The FS Line cabinets offer you a flexible and comprehensive solution for your server installations In terms of housing, you have numerous 19" options with installation depths that range from 600 to 800 mm: With heights from 16 to 42 units in black (RAL9005) or gray (RAL7035). With automated Silk U Numbering. It's design features provide 4 way access to your enclosure and equipments, easy to reach to enclosure and equipments for all infrastucture installations and maintenance needs.

In material and workmanship, we provide top quality. Part of that is a cold-rolled steel frame, zinc-plated 19" mounting rails and antistatic powder coating on all panels.

Construction

Door: Perforated Single and Double Opening Front and Rear door options up to 80% perforation.

Material: A1 quality steel HDG, carriers are 1.5 mm (2.00mm option is available for heavy duty – Loading Capacity 1200kg), mounting rails 1.5 mm – Loading Capacity 800kg.

Cable Entry: On Top and bottom cable entry. Multiple cable entry points provide maximum versatility

Mounting Rail: 4 Pcs = 2 Set (Right and Left) of 19" adjustable mounting rails. Compatible with standard international 19 inch standard.

Side Panels: Opening & lockable Split Panels.

Painting: Impact-resistant, Electrostatic powder painting. Color options are RAL 9005 Black & RAL 7035 White.

IP 20 rating: IP20 according to EN61587-1, IEC60529. Protected against solid objects larger than 12,5 mm in diameter.

Heights: 12U, 15U, 16U, 19U, 20U, 25U, 27U, 30U 33U 35U 37U 39U 42U 45U 47U

Width & Depth:

- 600x600mm
- 600x800mm
- 600x1000mm
- 800x800mm
- 800x1000mm

This document is a property of UPCOM Telekom and must not be copied or damaged in any form, wholly or in part w/o written permission from UPCOM Telekom specifications indicated in this document are not contractual and can be modified w/o notification.



Drawing

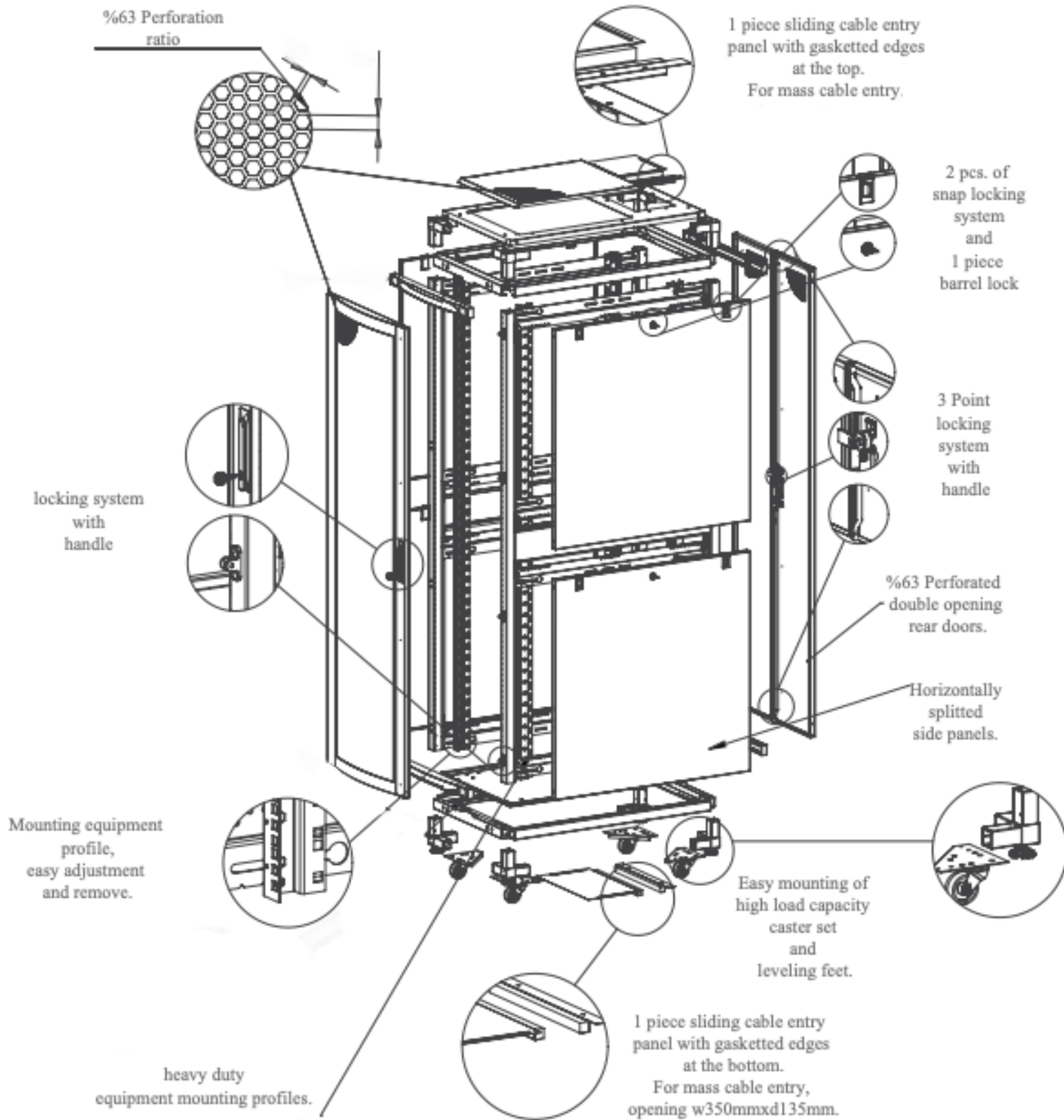

This document is a property of UPCOM Telekom and must not be copied or damaged in any form, wholly or in part w/o written permission from UPCOM Telekom specifications indicated in this document are not contractual and can be modified w/o notification.



Compliance

- ISO 9001:2000 TSE:EN 61587-1 Mechanical Structures For Electronic Equipment - Tests For IEC 60917 And IEC 60297
- Climatic and Environment: EN 61587-1/4.2, IEC60068-2-1, IEC60068-2-2, IEC60068-2-30,
- Static Mechanical Load Lifting: EN61587-1/5.2.1
- Static Mechanical Load Stiffness: EN61587-1/5.2.2
- Dynamic Mechanical Load Vibration and Shock, Impact: EN61587-1/5.3.1, EN61587-1/5.3.3, IEC60068-2-6, IEC60068-2-27,
- Earth Bond: EN61587-1/6.2
- Flammability: EN61587-1/6.3
- Degrees Of Protection Provided By Enclosures (Ip Code): IP20 or IP55, EN61587-1/6.4
- Load Carrying Capacity: 800kg or 1200kg Optional
- Surface Treatment: Fosfat coating
- Corrosion Resistance: ISO9227 and ASTM B 117-85
- Painting: Ral7035 / Ral9005



ISO 14001 Environmental
Management System
%100 Recyclable Material



CE conform to EN 60950-1:2006
Information Technology
Equipment – Safety – Part-1-



RoHS Compliancy

This document is a property of UPCOM Telekom and must not be copied or damaged in any form, wholly or in part w/o written permission from UPCOM Telekom specifications indicated in this document are not contractual and can be modified w/o notification.



Accessories frequently ordered with this item

Ordering Code	Fan Modules
UP-FAN-DJT-1-FS-CC	1xFan Module Digital Thermostat for FS Line
UP-FAN-DJT-2-FS-CC	2x Fan Module Digital Thermostat for FS Line
UP-FAN-DJT-4-FS-CC	4x Fan Module Digital Thermostat for FS Line
UP-FAN-DJT-6-FS-CC	6x Fan Module Digital Thermostat for FS Line
UP-FAN-ONF-1-FS-CC	1xFan Module with On/Switch for FS Line
UP-FAN-ONF-2-FS-CC	2xFan Module with On/Switch for FS Line
UP-FAN-ONF-4-FS-CC	4xFan Module with On/Switch for FS Line
UP-FAN-RM-DJT-1-UV-CC	Rack Mounting Type 1xFan Module with Digital Thermostat
UP-FAN-RM-DJT-2-UV-CC	Rack Mounting Type 2xFan Module with Digital Thermostat
Ordering Code	Power Distribution Units (PDUs)
UP-PRZ-SGT-1U-3P-SC	3xDIN49440 Socket Schuko Power Stripe, 19" 1U, aluminium housing, 1x16A cct breaker, 4000 Watt, 250V AC, 3x1.5mm ² , 2,5m cable, DIN 49441 plug, CE approval
UP-PRZ--SGT-1U-6P-SC	6xDIN49440 Socket Schuko Power Stripe, 19" 1U, aluminium housing, 1x16A cct breaker, 4000 Watt, 250V AC, 3x1.5mm ² , 2,5m cable, DIN 49441 plug, CE approval
UP-PRZ--SGT-1U-8P-SC	8xDIN49440 Socket Schuko Power Stripe, 19" 1U, aluminium housing, 1x16A cct breaker, 4000 Watt, 250V AC, 3x1.5mm ² , 2,5m cable, DIN 49441 plug, CE approval
UP-PRZ--SGT-2U-9P-SC	9xDIN49440 Socket Schuko Power Stripe, 19" 1U, aluminium housing, 1x16A cct breaker, 4000 Watt, 250V AC, 3x1.5mm ² , 2,5m cable, DIN 49441 plug, CE approval
UP-PRZ--SGT-2U-12P-SC	12xDIN49440 Socket Schuko Power Stripe, 19" 1U, aluminium housing, 1x16A cct breaker, 4000 Watt, 250V AC, 3x1.5mm ² , 2,5m cable, DIN 49441 plug, CE approval
UP-PRZ--SGT-1U-6P-UK	6xBS1363 UK Socket Power Stripe, 19" 1,5U, aluminium housing, 16A lighted on/off switched, 4000 Watt, 250V AC, 3x1.5mm ² , 2,5m cable, 13A BS1363 plug, CE approval
UP-PRZ--SGT-2U-9P-UK	9xBS1363 UK Socket Power Stripe, 19" 1,5U, aluminium housing, 16A lighted on/off switched, 4000 Watt, 250V AC, 3x1.5mm ² , 2,5m cable, 13A BS1363 plug, CE approval
UP-PRZ--SGT-2U-12P-UK	12xBS1363 UK Socket Power Stripe, 19" 1,5U, aluminium housing, 16A lighted on/off switched, 4000 Watt, 250V AC, 3x1.5mm ² , 2,5m cable, 13A BS1363 plug, CE approval
Ordering Code	Fixed & Sliding Shelves
UP-RAF-SBT-600-CC	Fixed Shelf - 4 fixing point, Physical Shelf Depth:300mm for D=600mm cabinets, Load Capacity 50 kg
UP-RAF-SBT-800-CC	Fixed Shelf - 4 fixing point, Physical Shelf Depth:500mm for D=800mm cabinets, Load Capacity 50 kg
UP-RAF-SBT-1000-CC	Fixed Shelf - 4 fixing point, Physical Shelf Depth:720mm for D=1000mm cabinets, Load Capacity 50 kg
UP-RAF-HRK-600-CC	Sliding Shelf - 4 fixing point, Physical Shelf Depth:300mm for D=600mm cabinets, Load Capacity 50 kg
UP-RAF-HRK-800-CC	Sliding Shelf - 4 fixing point, Physical Shelf Depth:500mm for D=800mm cabinets, Load Capacity 50 kg
UP-RAF-HRK-1000-CC	Sliding Shelf - 4 fixing point, Physical Shelf Depth:720mm for D=1000mm cabinets, Load Capacity 50 kg

This document is a property of UPCOM Telekom and must not be copied or damaged in any form, wholly or in part w/o written permission from UPCOM Telekom specifications indicated in this document are not contractual and can be modified w/o notification.



Ordering Code	Horizontal Cable Organizer
UP-KNC-ORG-1U-5R-CC	1U Cable Organizer with 5 Rings
UP-KNC-ORG-1U-5R-CC	2U Cable Organizer with 5 Rings
UP-KNC-ORG-1U-5R-BT-CC	1U Cable Organizer 5 Rings - Brushed Type
Ordering Code	Vertical Cable Organizer
UP-ORG-DKY-PLST-20U-60	20U Vertical Cable Tray Plastic For Free Standing Cabinets W:600
UP-ORG-DKY-PLST-25U-60	25U Vertical Cable Tray Plastic For Free Standing Cabinets W:600
UP-ORG-DKY-PLST-30U-60	30U Vertical Cable Tray Plastic For Free Standing Cabinets W:600
UP-ORG-DKY-PLST-33U-60	33U Vertical Cable Tray Plastic For Free Standing Cabinets W:600
UP-ORG-DKY-PLST-35U-60	35U Vertical Cable Tray Plastic For Free Standing Cabinets W:600
UP-ORG-DKY-PLST-42U-60	42U Vertical Cable Tray Plastic For Free Standing Cabinets W:600
UP-ORG-DKY-MTL-20U-80/100	20U Vertical Cable Tray Metallic For Free Standings Cabinets W:800 or W:1000
UP-ORG-DKY-MTL-25U-80/100	25U Vertical Cable Tray Metallic For Free Standings Cabinets W:800 or W:1000
UP-ORG-DKY-MTL-30U-80/100	30U Vertical Cable Tray Metallic For Free Standings Cabinets W:800 or W:1000
UP-ORG-DKY-MTL-33U-80/100	33U Vertical Cable Tray Metallic For Free Standings Cabinets W:800 or W:1000
UP-ORG-DKY-MTL-35U-80/100	35U Vertical Cable Tray Metallic For Free Standings Cabinets W:800 or W:1000
UP-ORG-DKY-MTL-42U-80/100	42U Vertical Cable Tray Metallic For Free Standings Cabinets W:800 or W:1000
Ordering Code	Screw Type Blank Panel
UP-KPM-VDL-1U-CC	1U 19" Blank Panel Screw Type
UP-KPM-VDL-2U-CC	2U 19" Blank Panel Screw Type
UP-KPM-VDL-3U-CC	3U 19" Blank Panel Screw Type
UP-KPM-VDL-4U-CC	4U 19" Blank Panel Screw Type
UP-KPM-VDL-5U-CC	5U 19" Blank Panel Screw Type
UP-KPM-VDL-6U-CC	6U 19" Blank Panel Screw Type
UP-KPM-VDL-7U-CC	7U 19" Blank Panel Screw Type
UP-KPM-VDL-8U-CC	8U 19" Blank Panel Screw Type
UP-KPM-VDL-9U-CC	9U 19" Blank Panel Screw Type
UP-KPM-VDL-10U-CC	10U 19" Blank Panel Screw Type
Ordering Code	Caster and Levelling Feet
UP-P.AYK-10-4	Leveling Feet Group, PVC 1 set=4 pcs, M10
UP-TKR-GRP-4	Free Standing Caster Set, 1 set=4 pcs, 2w/break, 2wo/break
Ordering Code	Fixings
UP-VD-SM-ST-20P	Screw 20pcs, Washer 20pcs, Cage nut 20pcs
UP-VD-SM-ST-50P	Screw 50pcs, Washer 50pcs, Cage nut 50pcs
UP-VD-SM-ST-100P	Screw 100pcs, Washer 100pcs, Cage nut 100pcs

This document is a property of UPCOM Telekom and must not be copied or damaged in any form, wholly or in part w/o written permission from UPCOM Telekom specifications indicated in this document are not contractual and can be modified w/o notification.



Ordering Code	Fixings
UP-VD-SM-ST-20P	Screw 20pcs, Washer 20pcs, Cage nut 20pcs
UP-VD-SM-ST-50P	Screw 50pcs, Washer 50pcs, Cage nut 50pcs
UP-VD-SM-ST-100P	Screw 100pcs, Washer 100pcs, Cage nut 100pcs
Ordering Code	Lighting
UP-AYD-UNT-1U-LED-ST	Lighting Module 1U 19", Cord switched, Fixing on the Cell with Screw
Ordering Code	Earth Quake Fixing Kit
UP-DSK-600	Earth Quake Fixing Kit 600MM
UP-DSK-800	Earth Quake Fixing Kit 800MM
UP-DSK-1000	Earth Quake Fixing Kit 1000MM
Ordering Code	Earthing Kit
UP-TPRK-ST-01	Grounding Set, 10 grounding point, 4pcsx4mm diameterx 40cm long yellow/green wires, for basic grounding of cabinet chasis and panels

This document is a property of UPCOM Telekom and must not be copied or damaged in any form, wholly or in part w/o written permission from UPCOM Telekom specifications indicated in this document are not contractual and can be modified w/o notification.